

Maximum Rating Tables

Size 818 • GR, NH, EL Series



Single Reduction
Worm Gear Reducers

Double Reduction
Worm - Worm Gear Reducers

Double Reduction
Helical - Worm Gear Reducers

WASHGUARD® Reducers
and GEAR+MOTOR™

Ratio Multipliers

Accessories and
Additional Capabilities

Style B

Style H

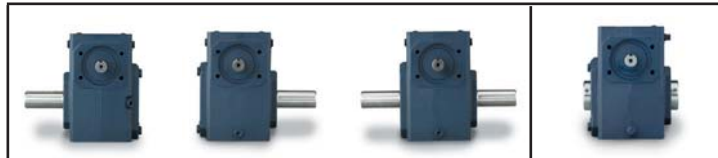

Size 818

Ratio	nput RPM	Output RPM	nput HP	Output HP	Output Torque (lb in)	Left Hand Catalog No	Right Hand Catalog No	Double Extension Catalog No	Hollow Output Catalog No *
5	2500	500	3 095	2 900	366	8180001	8180013	8180025	8180501.XX
	1750	350	2 600	2 422	436				
	1170	234	2 066	1 906	513				
7.5	100	20	0 312	0 228	717	8180002	8180014	8180026	8180502.XX
	2500	333	2 307	2 127	402				
	1750	233	1 909	1 745	471				
10	1170	156	1 473	1 328	537	8180003	8180015	8180027	8180503.XX
	100	13	0 227	0 147	697				
	2500	250	1 996	1 820	459				
15	1750	175	1 625	1 466	528	8180004	8180016	8180028	8180504.XX
	1170	117	1 239	1 099	592				
	100	10	0 196	0 118	744				
20	2500	166	1 485	1 301	492	8180005	8180017	8180029	8180505.XX
	1750	116	1 224	1 058	571				
	1170	78	0 945	0 799	645				
25	100	6 7	0 165	0 087	823	8180006	8180018	8180030	8180506.XX
	2500	125	1 283	1 093	551				
	1750	87	1 046	0 875	630				
30	1170	58	0 803	0 652	702	8180007	8180019	8180031	8180507.XX
	100	5 0	0 150	0 069	872				
	2500	100	1 088	0 900	567				
40	1750	70	0 884	0 715	644	8180008	8180020	8180032	8180508.XX
	1170	46	0 678	0 530	713				
	100	4 0	0 135	0 055	874				
50	2500	83	0 892	0 702	531	8180009	8180021	8180033	8180509.XX
	1750	58	0 741	0 569	614				
	1170	39	0 580	0 428	692				
60	100	3 3	0 126	0 047	880	8180010	8180022	8180034	8180510.XX
	2500	62	0 739	0 551	556				
	1750	43	0 609	0 440	634				
80	1170	29	0 476	0 328	706	8180011	8180023	8180035	8180511.XX
	100	2 5	0 113	0 035	874				
	2500	50	0 625	0 444	559				
100	1750	35	0 515	0 352	634	8180012	8180024	8180036	8180512.XX
	1170	23	0 404	0 260	701				
	100	2 0	0 103	0 027	857				
100	2500	41	0 542	0 363	550	8180012	8180024	8180036	8180512.XX
	1750	29	0 449	0 288	623				
	1170	19	0 354	0 213	689				
100	100	1 7	0 097	0 022	842	8180011	8180023	8180035	8180511.XX
	2500	31	0 247	0 156	314				
	1750	21	0 208	0 124	356				
100	1170	14	0 164	0 091	392	8180012	8180024	8180036	8180512.XX
	100	1 3	0 023	0 009	470				
	2500	25	0 167	0 097	245				
100	1750	17	0 141	0 077	277	8180012	8180024	8180036	8180512.XX
	1170	11	0 111	0 057	304				
	100	1 0	0 016	0 006	362				

How To Build a Part Number For Size GR818, NH818 & EL818

1. Select partial catalog number from the selection table
2. Replace leading “_” with series code (GR, NH, EL)
3. For hollow output, replace “XX” suffix with bore code (see next page for codes)

Example:

Grove Gear IRONMAN, style B, 5:1 ratio, left hand output
GR-B818-5-L
GR8180001



Maximum Rating Tables

Size 818 • GR, NH, EL Series

Single Reduction
Worm Gear Reducers

Double Reduction
Worm - Worm Gear Reducers

Double Reduction
Helical - Worm Gear Reducers

WASHGUARD® Reducers
and GEAR+MOTOR™

Ratio Multipliers

Accessories and
Additional Capabilities

NEMA C nput Flange ▲	Style BM			Style HM	Style BMQ			Style HMQ	Ratio
	Left Hand Catalog No	Right Hand Catalog No	Double Extension Catalog No	Hollow Output Catalog No *	Left Hand Catalog No	Right Hand Catalog No	Double Extension Catalog No	Hollow Output Catalog No *	
56C 143 5TC	8180037 8180073	8180049 8180085	8180061 8180097	8180513.XX 8180525.XX	8180109 8180145	8180121 8180157	8180133 8180169	8180537.XX 8180549.XX	5
56C 143 5TC	8180038 8180074	8180050 8180086	8180062 8180098	8180514.XX 8180526.XX	8180110 8180146	8180122 8180158	8180134 8180170	8180538.XX 8180550.XX	7.5
56C 143 5TC	8180039 8180075	8180051 8180087	8180063 8180099	8180515.XX 8180527.XX	8180111 8180147	8180123 8180159	8180135 8180171	8180539.XX 8180551.XX	10
56C 143 5TC	8180040 8180076	8180052 8180088	8180064 8180100	8180516.XX 8180528.XX	8180112 8180148	8180124 8180160	8180136 8180172	8180540.XX 8180552.XX	15
56C 143 5TC	8180041 8180077	8180053 8180089	8180065 8180101	8180517.XX 8180529.XX	8180113 8180149	8180125 8180161	8180137 8180173	8180541.XX 8180553.XX	20
56C 143 5TC	8180042 8180078	8180054 8180090	8180066 8180102	8180518.XX 8180530.XX	8180114 8180150	8180126 8180162	8180138 8180174	8180542.XX 8180554.XX	25
56C 143 5TC	8180043 8180079	8180055 8180091	8180067 8180103	8180519.XX 8180531.XX	8180115 8180151	8180127 8180163	8180139 8180175	8180543.XX 8180555.XX	30
48CZ 56C 143 5TC	8180188 8180044 8180080	8180200 8180056 8180092	8180212 8180068 8180104	8180568.XX 8180520.XX 8180532.XX	8180224 8180116 8180152	8180236 8180128 8180164	8180248 8180140 8180176	8180580.XX 8180544.XX 8180556.XX	40
48CZ 56C 143 5TC	8180189 8180045 8180081	8180201 8180057 8180093	8180213 8180069 8180105	8180569.XX 8180521.XX 8180533.XX	8180225 8180117 8180153	8180237 8180129 8180165	8180249 8180141 8180177	8180581.XX 8180545.XX 8180557.XX	50
48CZ 56C 143 5TC	8180190 8180046 8180082	8180202 8180058 8180094	8180214 8180070 8180106	8180570.XX 8180522.XX 8180534.XX	8180226 8180118 8180154	8180238 8180130 8180166	8180250 8180142 8180178	8180582.XX 8180546.XX 8180558.XX	60
48CZ 56C	8180191 8180047	8180203 8180059	8180215 8180071	8180571.XX 8180523.XX	8180227 8180119	8180239 8180131	8180251 8180143	8180583.XX 8180547.XX	80
48CZ 56C	8180192 8180048	8180204 8180060	8180216 8180072	8180572.XX 8180524.XX	8180228 8180120	8180240 8180132	8180252 8180144	8180584.XX 8180548.XX	100

For input/ output shaft overhung load and thrust load ratings, refer to pages 419-422.

▲ Consult Factory for other motor flanges available.

* Catalog numbers are for hollow output shaft reducers.

When ordering, substitute the XX suffix with the required output bore code.

Available bore codes

Fraction Size	5/8"	11/16"	3/4"	7/8"	1"
Decimal Size	0.625	0.688	0.750	0.875	1.000
Output Bore Code	10	11	12	14	16



GR Series Dimensions

Styles: HMQ, HM, H

CAST IRON
GR SERIES

Style HMQ

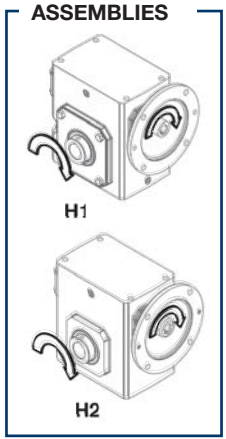
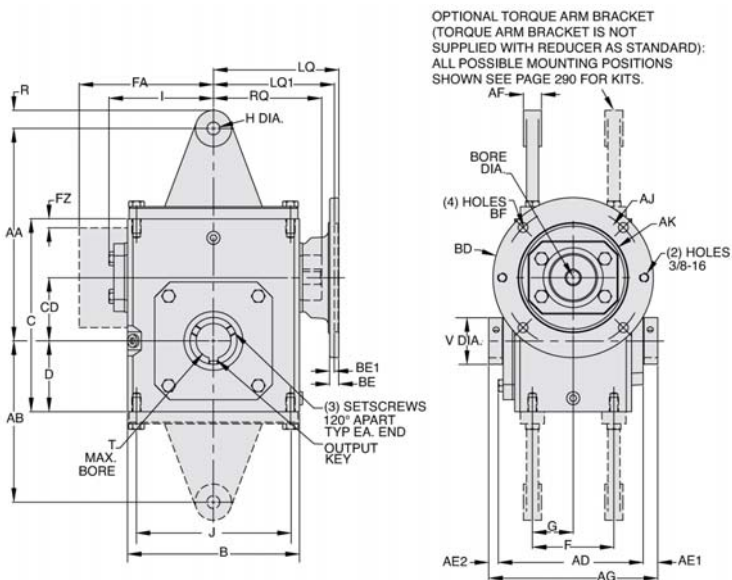

H1 SUPPLIED AS STANDARD UNLESS SPECIFIED.

Style HM

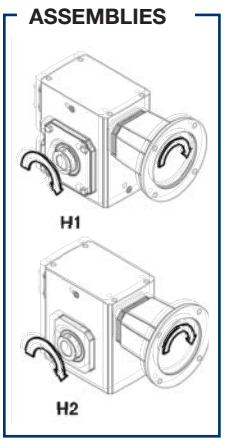
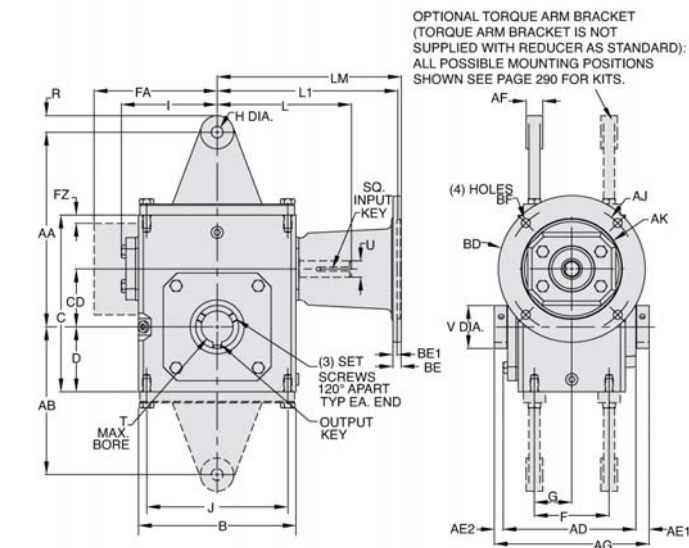

H1 SUPPLIED AS STANDARD UNLESS SPECIFIED.

Style H

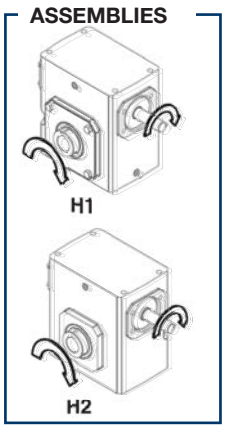
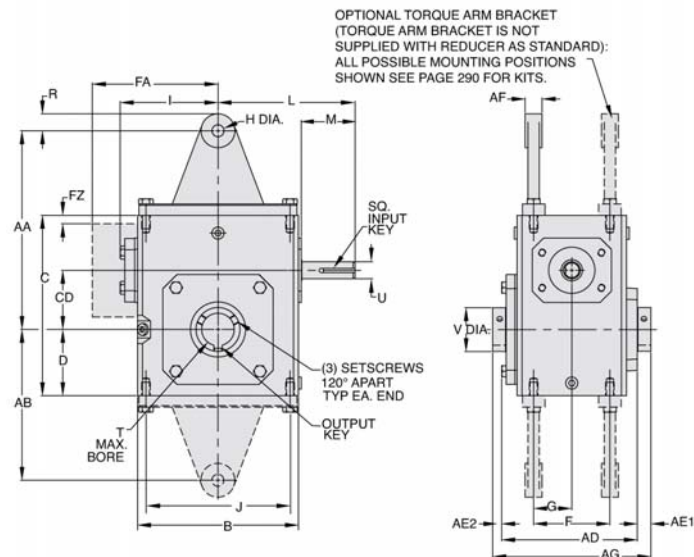

REVERSE ALL ARROWS FOR OPPOSITE INPUT SHAFT ROTATION. CONTACT FACTORY FOR OTHER MOUNTINGS OR ASSEMBLY POSITIONS.

H1 SUPPLIED AS STANDARD UNLESS SPECIFIED.

Single Reduction
Worm Gear Reducers

Double Reduction
Worm - Worm Gear Reducers

Double Reduction
Helical - Worm Gear Reducers

WASHGUARD® Reducers
and GEAR+MOTOR™

Ratio Multipliers

Accessories and
Additional Capabilities



STYLE HMQ, HM, H DIMENSIONS (Inches)

Series	AD	AE1	AE2	AG	B	C	D	CD	F	FA▼	FZ▼	G	I	J	L	M	V	T MAX -0.000 +0.0025	U +0.000 -0.0015	Input Key*	Output Key +
GR813	3.90	0.53	0.32	4.75	3.80	4.66	1.72	1.33	2.00	N/A	N/A	1.00	2.61	3.25	3.82	1.76	1.000	0.625	0.500	1/8 x 1.00	3/16 x 1.50
GR815	4.61	0.51	0.30	5.42	5.19	5.38	1.91	1.54	2.75	N/A	N/A	1.38	3.14	4.19	4.35	1.76	1.000	0.625	0.625	3/16 x 1.38	3/16 x 1.50
GR818	4.73	0.49	0.28	5.50	5.19	5.75	2.06	1.75	2.75	N/A	N/A	1.38	3.24	4.19	4.45	1.76	1.440	1.000	0.625	3/16 x 1.38	1/4 x 3.00
GR821	4.99	0.61	0.40	6.00	5.80	6.38	2.28	2.06	▲	N/A	N/A	1.44	3.61	▲	4.82	1.76	1.940	1.500	0.625	3/16 x 1.38	3/8 x 3.00
GR824	5.18	0.51	0.31	6.00	6.12	6.94	2.50	2.38	2.88	N/A	N/A	1.44	3.77	5.00	5.51	2.38	1.940	1.500	0.750	3/16 x 1.63	3/8 x 3.00
GR826x	6.01	0.60	0.39	7.00	7.38	8.00	2.94	2.63	3.38	N/A	N/A	1.69	4.34	6.38	6.07	2.38	1.940	1.500	0.750	3/16 x 1.63	3/8 x 3.00
GR830	6.53	0.60	0.36	7.50	8.12	8.88	3.25	3.00	4.00	N/A	N/A	2.00	4.84	7.00	6.57	2.38	2.756	2.188	0.875	3/16 x 1.63	1/2 x 3.00
GR832x	7.04	0.54	0.29	7.88	8.75	9.38	3.50	3.25	4.00	N/A	N/A	2.00	5.02	7.50	6.76	2.38	2.756	2.188	0.875	3/16 x 1.63	1/2 x 3.00
GR842	7.53	0.63	0.34	8.50	10.25	11.38	4.44	4.25	5.00	N/A	N/A	2.50	6.10	8.50	9.57	3.47	2.756	2.188	1.250	1/4 x 2.50	1/2 x 3.00
GR852	8.85	0.97	0.68	10.50	13.00	14.00	5.12	5.25	5.81	N/A	N/A	2.91	7.50	11.00	10.88	3.38	4.260	3.438	1.250	1/4 x3.00	7/8 x3.44
GR860	10.52	0.52	0.52	11.50	14.50	16.50	6.50	6.00	6.38	11.13	0.33	3.19	N/A	12.75	11.78	3.41	4.256	3.438	1.500	3/8 x 3.00	7/8 x 3.44
GR870	11.36	1.09	1.09	13.50	14.88	18.91	7.59	7.00	5.50	11.37	0.35	2.75	N/A	12.50	11.50	2.97	4.928	3.938	1.625	3/8 x 2.87**	1 x 1/2**
GR880	12.48	1.03	1.03	14.50	17.00	20.96	8.86	8.00	6.50	12.52	0.57	3.25	N/A	14.25	12.50	2.84	5.553	4.438	1.875	1/2 x 2.81**	1 x 1/2**
GR8100	15.78	1.39	1.39	18.50	20.88	25.47	10.36	10.00	6.88	14.69	0.51	3.44	N/A	14.75	15.50	3.76	4.256	5.438	2.250	1/2 x 3.69**	1-1/4 x 5/8**

▲ See feature comparison chart.

FEATURE COMPARISON (821)

Size	Output Shaft Diameter Needed?	Mounting Footprint Needed?	Output Key Needed?	All Other Features	Grove Gear Flexaline Interchange	LEESON IRONMAN Interchange	Replace With Series Code Below:
GR821	Identical	(F)3.00" x (J)4.75" (F)2.88" x (J)5.00"	Identical	Identical	✓	✓	GRG GRL

NOTE: If reducer is used without the accessory mounted, select based mounting dimensions on pages 52-53 (B, BM, BMQ).

**Motor Mounting Dimensions
NEMA DIMENSIONS (Inches)**

Size	48CZ	LM	56C/140TC	180TC/210TC	L1	250TC	LQ	48CZ/56C/140TC	180TC	LQ1	210TC	250TC	48CZ/56C/140TC	180TC	210TC	250TC
GR813	5.63	6.07	N/A	N/A	N/A	N/A	3.46	N/A	N/A	N/A	N/A	N/A	3.09	N/A	N/A	N/A
GR815	6.16	6.60	N/A	N/A	N/A	N/A	3.99	N/A	N/A	N/A	N/A	N/A	3.62	N/A	N/A	N/A
GR818	6.26	6.70	N/A	N/A	N/A	N/A	4.09	N/A	N/A	N/A	N/A	N/A	3.59	N/A	N/A	N/A
GR821*	6.63	7.07	N/A	N/A	N/A	N/A	4.46	N/A	N/A	N/A	N/A	N/A	4.06	N/A	N/A	N/A
GR824	N/A	7.76	8.76	N/A	4.63	5.06	N/A	4.09	4.56	N/A	N/A	N/A	4.09	4.56	N/A	N/A
GR826*	N/A	8.32	9.32	N/A	5.19	5.62	N/A	4.82	5.13	N/A	N/A	N/A	5.13	N/A	N/A	N/A
GR830	N/A	8.82	9.82	N/A	5.95	6.15	6.56	N/A	5.32	5.63	6.06	N/A	5.63	6.06	N/A	N/A
GR832*	N/A	9.01	10.01	N/A	6.14	6.34	6.75	N/A	5.51	5.81	6.25	N/A	5.81	6.25	N/A	N/A
GR842	N/A	11.81	12.90	13.46	6.45	7.21	7.21	7.77	6.04	6.68	6.68	7.24	6.68	6.68	7.24	7.24
GR852	N/A	13.21	14.30	14.86	7.85	8.61	8.61	9.17	7.35	7.98	7.98	8.54	7.98	7.98	8.54	8.54
GR860	N/A	N/A	15.88	16.50	10.45	9.33	9.33	9.94	10.01	8.69	8.69	8.69	8.69	8.69	8.69	8.69
GR870	N/A	N/A	15.50	15.50	N/A	N/A	N/A	N/A	N/A	N/A	N/A	N/A	N/A	N/A	N/A	N/A
GR880	N/A	N/A	16.58	16.58	N/A	N/A	N/A	N/A	N/A	N/A	N/A	N/A	N/A	N/A	N/A	N/A

NEMA DIMENSIONS (Inches)

Frame	AJb	AK	BD	BE	BE1	Bore Dia.	Keyway♦	BFb
	3.75	3.00	4.36	0.38	N/A	.500	1/8 X 1/16	0.28
56C	5.88	4.50	6.50	0.38	N/A	.625	3/16 X 3/32	0.41
140TC	5.88	4.50	6.50	0.38	N/A	.875	3/16 X 3/32	0.41
180TC	7.25	8.50	9.00	N/A	0.50	1.125	1/4 X 1/8	0.53
210TC	7.25	8.50	9.00	N/A	0.50	1.375	5/16 X 5/32	0.53
250TC	7.25	8.50	9.00	N/A	0.50	1.625	3/8 X 3/16	0.53

IEC B5 & B3/B5 METRIC DIMENSIONS (Inches)*

Size	LQ1						RQ					
	D63D	D71D	D80D	D90D	D100LD/D112MD	D132D	D63D	D71D	D80D	D90D	D100LD/D112MD	D132D
GR813	2.62	2.65	2.89	N/A	N/A	N/A	2.45	2.47	2.71	N/A	N/A	N/A
GR815	3.15	3.18	3.42	N/A	N/A	N/A	2.98	3.00	3.24	N/A	N/A	N/A
GR818	3.25	3.28	3.52	N/A	N/A	N/A	2.95	2.97	3.21	N/A	N/A	N/A
GR821*	3.62	3.65	3.89	N/A	N/A	N/A	3.43	3.44	3.68	N/A	N/A	N/A
GR824	N/A	3.72	4.34	N/A	N/A	N/A	3.46	3.71	N/A	N/A	N/A	N/A
GR826*	N/A	4.28	4.90	4.90	5.30	N/A	N/A	4.09	4.72	4.72	5.07	N/A
GR830	N/A	4.78	5.41	5.41	5.88	N/A	N/A	4.59	5.22	5.22	5.57	N/A
GR832*	N/A	4.97	5.59	5.59	6.07	N/A	N/A	4.78	5.41	5.41	5.76	N/A
GR842	N/A	N/A	N/A	6.38	6.39	7.17	N/A	N/A	N/A	6.16	6.14	6.93
GR852	N/A	N/A	N/A	7.78	7.78	8.57	N/A	N/A	N/A	7.46	7.45	8.24

IEC B5 & B3/B5 METRIC DIMENSIONS (MM)

Frame	AJ	AK	BD	BE	Bore Dia.	Keyway♦	BF TAP	OD
D63D	115	95	117	10	11	4 X 2	M8 X 1.25	131
D71D	130	110	132	11	14	5 X 2.5	M8 X 1.25	146
D80D	165	130	165	15	19	6 X 3	M10 X 1.50	184
D90D	165	130	165	15	24	8 X 3.5	M10 X 1.50	184
D100LD/D112MD	215	180	216	18	28	8 X 3.5	M12 X 1.75	237
D132D	265	230	267	18	38	10 X 4	M12 X 1.75	290

* Max bore dimensions shown. For additional bores available, refer to page 20.

* Applies to double output shaft

** Key not provided with gear reducer. Keyway dimension shown.

♦ Keyway width by depth

⊙ Mounting holes rotated 45 degrees from positions shown on Size GR860, Style HM with frame sizes 180TC-250TC.

■ 48CZ not available

● 180TC not available

⊕ Metric IEC B5 input flange options are available only on quill input styles.

* Dimensions same for GRG and GRL Series

* Style H and HM only.

▼ Sizes 860-8100 are supplied with a fan. Dimensions refer to fan guard location.

Note: Torque arm bracket available separately. Refer to page 274 for kits. If a special bracket is required, refer to Style BMQ dimensions for mounting pad dimensions on top/bottom of reducer.



For safety, purchaser or user should provide protective guards over shaft extensions and any couplings, sheaves and belts, sprockets and chains, etc., mounted thereon.

Single Reduction
Worm Gear Reducers

Double Reduction
Worm - Worm Gear Reducers

Double Reduction
Helical - Worm Gear Reducers

WASHGARD® Reducers
and GEAR-HMOTOR™

Ratio Multipliers

Accessories and
Additional Capabilities